



Job _____ Item No. _____

Contact Toaster

standard SCT4000 SCT4000E
specialty model SCT4000E-RR



SCT4000E

DESCRIPTION

Star contact toasters are designed with speed and consistency in mind. The optional programmable electronic control means toasting buns the same way in any number of locations is as simple as plugging in a USB drive. The wide dual side design allows for a production speed unmatched by other toasters.

SPECIFICATIONS

The Star contact toaster will be constructed in the U.S.A. with a corrosion-resistant stainless steel body. Electronic controlled units will use a high-contrast color display, high limit switch, variable speed control for front and rear conveyors, and electronic temperature control. Analog units will be controlled by a bulb and cap thermostat and will also utilize a high limit switch. Electronic units will be capable of storing an unlimited number of product setups, and will run from default settings initially. The conveyors will be driven by independent stepper motors on the electronic model and a single AC motor on the analog model. The conveyors will use single-piece silicone belts, and will be removable for cleaning. The units will be capable of running in a range between 208 V and 240 V, and will be single phase. The toaster will use a NEMA 6-15P plug. The plate will operate at temperatures up to 550°F (288°C).

WARRANTY

These units come with a one [1] year warranty against defect for both parts and labor. Wear parts will only be replaced under this warranty if failure is the result of a manufacturing defect.

FEATURES

- Dual, wide slot toasting makes the toaster capable of producing up to 1,800 buns per hour¹ [running two heels and two crowns at once with constant feed]
- First bun[s] pass-through time is as low as 12 seconds fully caramelized¹
- Bun height adjustment controlled with an easily adjusted twist knob ranging from 0.125 in. (3 mm) to 1 in. (25 mm) [adjusted independently front and rear]
- Supplied with an easy-to-install non-stick sheet
- Single piece front and rear silicone belts

OPTIONAL ELECTRONIC CONTROL VERSION ONLY

- High-contrast digital display allows for an infinite number of programmed product settings and instant adjustments to speed and set point temperature up to 550°F (288°C)
- USB port programming allows easy uploading of new product files and consistent results across any number of toasters and [product files can also be programmed on unit using control]
- Electronic control allows for independent speed control for front and rear belts
- Advanced stepper motor technology for precise speed control and with no gears to strip, translates to a long life

OPTIONS AND ACCESSORIES

- Programmable electronic speed and heat control
- 10-pack of replacement PTFE non-stick sheets [part number SCTSHEET-B]
- Replacement conveyor belt [part number SCTBELT]
- Butter wheel
 - perforated version [part number SCTBWP]
 - smooth version [part number SCTBWS]

CERTIFICATIONS



STAR MANUFACTURING INTERNATIONAL INC.
265 Hobson Street • Smithville, Tennessee 37166
Telephone 888 356 5362 • Fax 314 781 5445
www.star-mfg.com

¹Time will vary depending on bread type and desired result.

Printed in the U.S.A. • 2M-Z1296 • Rev D • 02.2018
Specifications are subject to change without notice and are not intended for installation purposes.

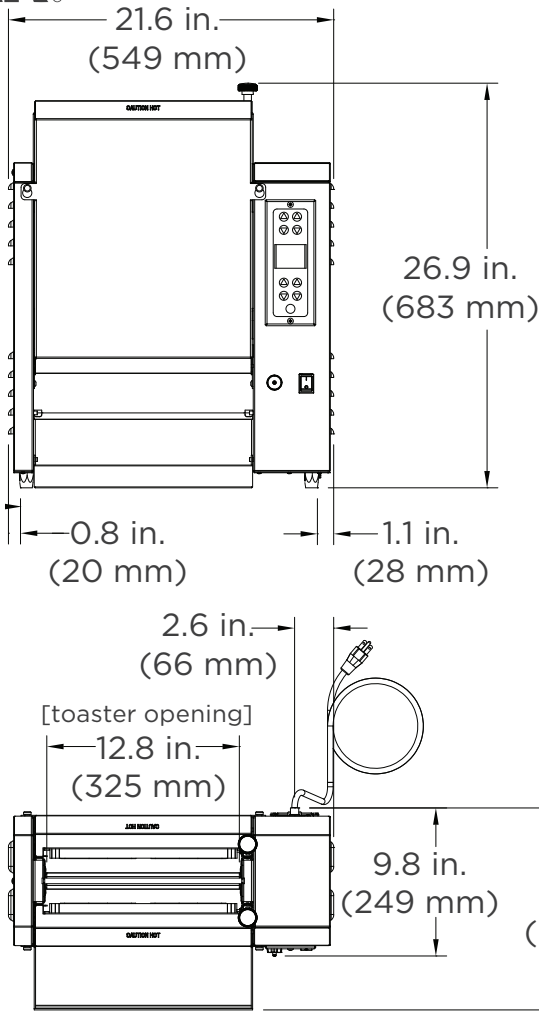

[minimum space to open front or rear conveyor covers]

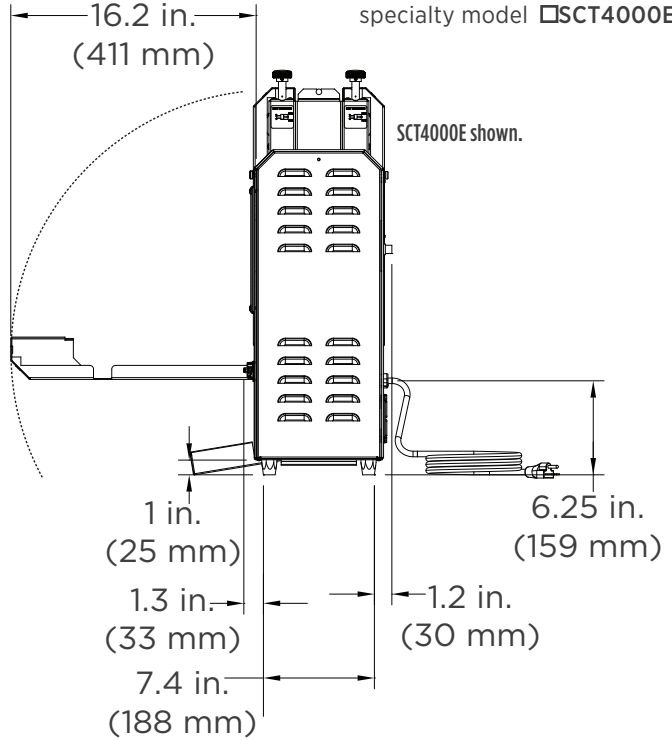

Contact Toaster

standard □SCT4000 □SCT4000E
specialty model □SCT4000E-RR

CLEARANCE

Please allow at least one [1] inch (25 mm) on each side of unit and the rear of the unit.

MODEL	HEIGHT	WIDTH	DEPTH ²	VOLTS	AMPS	WATTS	APPROX. SHIP WEIGHT	APPROX. WEIGHT INSTALLED
SCT4000E and SCT4000E-RR	26.9 in. (683 mm)	21.6 in. (549 mm)	9.8 in. (249 mm)	208	9.6	2,000	100 lb. (45.4 kg)	75 lb. (34 kg)
				230	10.6	2,446		
				240	11.1	2,663		
SCT4000	26.9 in. (683 mm)	21.6 in. (549 mm)	9.8 in. (249 mm)	208	9.9	2,065	100 lb. (45.4 kg)	75 lb. (34 kg)
				230	11	2,525		
				240	11.5	2,750		

²without bun tray [extends out and adds 3.6 in. (91 mm) to unit's base depth] or optional butter wheel [butter wheel extends out and adds 4.2 in. (107 mm) to unit's base depth].

Units sold for use in the U.S.A. and Canada will come with a factory-attached cord using a 6-15P plug.



6-15P

Due to periodic changes in designs, methods, procedures, policies and regulations, the specifications contained in this sheet are subject to change without notice. While Star Manufacturing exercises good faith efforts to provide information that is accurate, we are not responsible for errors or omissions in information provided or conclusions reached as a result of using the specifications. By using the information provided, the user assumes all risks in connection with such use.



STAR MANUFACTURING INTERNATIONAL INC.
265 Hobson Street • Smithville, Tennessee 37166
Telephone 888 356 5362 • Fax 314 781 5445
www.star-mfg.com

Printed in the U.S.A. • 2M-Z21296 • Rev D • 02.2018
Please refer to the owner's manual for information regarding installation or use.